

## KEY REGISTERS AS BASE OF THE DUTCH SDI

*BAKKER N.J.*

*Kadaster, APELDOORN, NETHERLANDS*

**This paper reports on the realisation of the Key Registers in the Netherlands as the foundation of the Dutch National Spatial Data Infrastructure (NSDI) and role that the INSPIRE Directive fulfills in this process.**

### Introduction

The Cadastre, Land Registry and Mapping Agency (Kadaster) is responsible for maintaining the different Key Registers in the Netherlands. A Key Register is a system that houses data information essential for the public sector. After several years of preparation the Dutch government has defined 13 Key Registers. They are from both the geo-information field as the non-geo-information field. The first 6 Registers are: Register of Persons, Cadastral Register, Register of Companies, Register of Addresses, Register of Buildings and Register of Topography. In the coming years other Registers will follow including the Register of Large Scale Topography (1:1,000) and Register of Subsoil (geology and soil).

The public agency that is most appropriate for the type of data in question will be legally acknowledged and responsible for the administration. The Dutch Cadastre is responsible for the Registers Cadastral Parcels and Topography. The municipalities are responsible for the Registers of Natural Persons, Addresses and Buildings and also in the future mainly for the Large Scale Topography. The Chamber of Commerce is responsible for the Register of Companies.

Another stimulating factor that must be taken into account whilst realising a national spatial data infrastructure, is the European Directive INSPIRE. It is required by law that all European Union countries implement INSPIRE into national legislation and in order to do so some requirements need to be fulfilled. Geographical datasets need to be harmonised and a webportal to house 34 datasets in Europe needs to be realised. In addition and perhaps the most challenging is the fact that governmental organisations which use and/or produce geographic information need to work together.

The Dutch Key Registers have special requirements. The use of the data will be mandatory throughout the entire government sector, as there are several ministries, provinces, municipalities and water boards. Also the users have obligations. They have to report back when they find errors in the dataset. This paper reports on the realisation of the Key Registers in the Netherlands as the foundation of the Dutch National Spatial Data Infrastructure (NSDI), their principles and the consequences for each organisation for updating and delivering data to the users.

### **National Spatial Data Infrastructure**

Over the last few years Spatial Data Infrastructures (SDIs) have become an important aspect of Geo-Information applications in all kinds of society. All over the world countries and regions are formalizing National Spatial Data Infrastructures (NSDI's).

The goal of this Infrastructure is to reduce duplication of effort among agencies, improve quality and reduce costs related to geographic information, to make geographic data more accessible to the public, to increase the benefits of using available data, and to establish key partnerships with countries, cities, academia and the private sector to increase data availability.

### **GIDEON – Key geo-information facility for the Netherlands**

In recent years, spatial data (or geo-information) has become increasingly important to society as a whole. Geo-information is used in electronic applications regarding agriculture, spatial planning, navigation, water management, environmental management, and many others (see figure 1).



Figure 1 The geo-information market

Therefore, geo-information has a prominent place in governmental public services as it reduces administrative burdens on the public and industry. The Dutch Government has produced an implementation strategy for geo-information in The Netherlands, known as Gideon. The Gideon document explains how public sector parties have created a key geo-information facility enabling them to be responsible for managing and using spatial information for the Netherlands. The objective is to achieve optimum utilization of geo-information by public authorities, business and citizens in the Netherlands.

The objectives of Gideon include:

- Public and businesses are able to retrieve and use all relevant geo-information;
- Businesses are able to add economic value to public sector geo-information;
- Government will use information for location related work processes and services;
- Continuing development and innovation of the key facility.
- Embedding geo in E-Government
- Reduce administrative burden
- Service for companies and citizens
- Effective and efficient government

The report defines 7 strategies for implementing the Dutch national spatial data infrastructure (see figure 2).



*Figure 2 The Gideon report*

The seven strategies of Gideon are to:

1. Give geo-information an appropriately prominent place within e-services;
2. Encourage the use of the existing Key Geo-Registers, and to set up new ones;
3. Embed the INSPIRE Directive into Dutch legislation and to implement the technical infrastructure;
4. Optimize supply by forming a government-wide geo-information facility, which is to include geo-data standardization, new infrastructure, and collaborative maintenance;
5. Encourage the use of geo-information in numerous government policy and implementation chains, such as safety, the sustainable living environment, mobility, and area development;
6. Create a favourable climate for adding economic value to available public authority geo-information;
7. Encourage collaboration in knowledge, innovation and education, for the permanent development and renewal of the key geo-information facility for the Netherlands.

One of the strategies of Gideon is the establishing of Key Registers.

### **Key Registers in the Netherlands**

In the 1990's, initiatives were started to realise Key Registers for essential administrations of the Netherlands. Both geographical and non-geographical (administrative) data were defined. Information exchange is very important in the direct contact between government and citizens and businesses. Reliable and accurate data are necessary for reacting to questions from citizens and companies, for adequate policy development and for maintaining security. One goal is that citizens and businesses provide data to the government only one time. The national and local authorities then have the obligation to exchange the data within their administrations. Another reason for establishing Key Registers is the fact that there are innumerable governmental databases, all being controlled by their own authority, without possibilities to exchange data between these authorities.

Now different public organisations are working hard to set up Key Registers. There are 12 general conditions for establishing a Key Register:

- Key Registers are regulated and established under Dutch law.
- Governmental organisations are obligated by law to use them.
- Governmental users are obligated by law to report errors or other irregularities.
- Liability
- Financing is arranged.
- Content of the datasets is well defined and catalogues are available.
- Procedures and standards for data distribution are clear.

- Accessibility is guaranteed.
- Quality of the data is assured.
- Involvement by governmental organisations is obliged.
- Relations between Key Registers are defined by keeping in mind ‘Capture data once, use many times’
- Control and responsibilities are covered by reliable organisations.

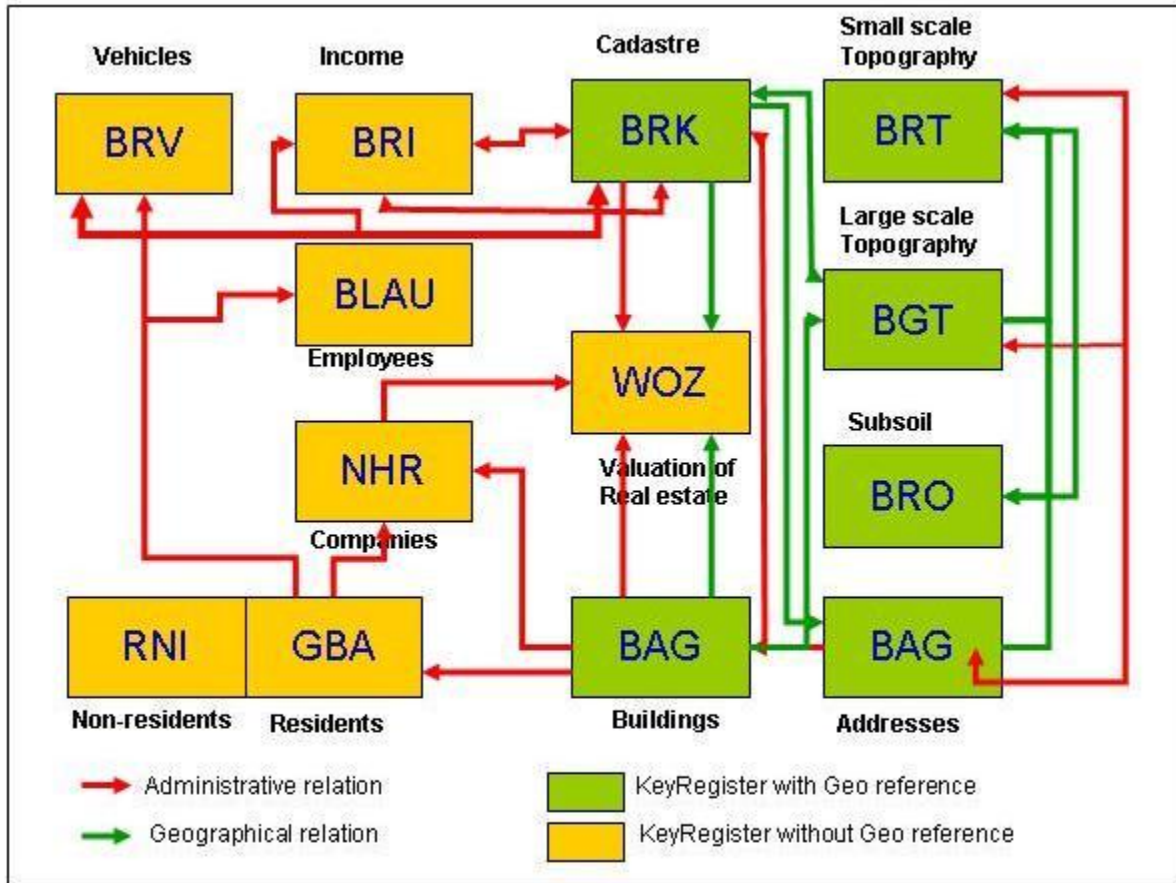

Figure 3 System of Key Registers

Key Registers contain the most requested and used data such as personal data, addresses, company names and coordinates of a location. Key Registers help national governments to avoid asking citizens or companies to provide the same data many times. Examples include address change, company name changes or the sale of a parcel. Authorities gather this data once in the Key Register of Registrations and use as necessary.

There are 13 Key Registers, which together make up the System of Key Registers (see figure 3). All municipalities, provinces and for example water boards must use these Registers for their public tasks. Governments can view this data through the national provision of the Kadaster.

#### **Key Registers with a geographical component**

##### Key Register Cadastral Parcels (BRK)

The Key Register Cadastre consists of the cadastral registration and cadastral map. Many customers use cadastral data as a basis for their own work processes. The Register can be linked to other Registers in order to exchange data.

##### Key Register Topography (BRT)

The Key Register Topography consists of digital topographic data sets at different scales. TOP10NL, the digital topographic dataset at the scale 1: 10,000 is the most used. The derived/generalised topographic data sets at the scales 1:50,000 , 1:100,000 , 1: 250,000 , 1: 500,000 and 1:1,000,000 are a part of the Key Register Topography since 1st January 2010. With the introduction of TOP10NL, a large number of technical and substantive renewals are realised in the field of topographical data. It is one of the first object-oriented topographical databases in Europe.

### Key Register Addresses and Buildings (consists of two Key Registers) (BAG)

The Key Register Addresses and Buildings (BAG) is also part of the System of Key Registers. The law determines that municipalities register basic information about buildings and addresses in an automated system. All municipalities make these data available through a national provision (BAGLV). Kadaster manages the national provision and makes the information available to various customers. The BAG improves governmental service to citizens and businesses. By sharing information between authorities, citizens and companies only have to pass a change of address to a municipality once. Also the BAG ensures that information of a property is fast and unambiguously available for example for emergency services and municipal institutions.

Municipalities are source managers of the BAG. They are responsible for recording data into the BAG in the required quality. The Key Register Adresses and Buildings (originally two separate Registers) was completed in 2011. The addresses contain all information about the municipality, place of residence (place name), street, house number and some other details. The municipality and place of residence (within the municipality) have geometrical coordinates. The other objects contain administrative information only. In the Key Register, addresses the buildings have detailed geometric information.

### New Commercial Register (NHR)

The NHR Register contains information on companies, social activities and their locations. The NHR provides a better service to entrepreneurs. They need to deliver their data only once to the Chamber of Commerce.

### Key Register Large-scale Topography (BGT)

In the Key Register Large-scale Topography (BGT), all objects present in a terrain are captured such as houses, roads and water courses. The BGT is a new Register based on the current Large-scale Base Map of the Netherlands (GBKN), but in order to meet the specification demands of a Key Register the content, structure and production organisation still has to be changed. The Register will probably be ready in 2015. Then all governments will be able to use the same basic set large-scale topography of the Netherlands.

### Key Register Subsoil (BRO)

The Key Register Subsoil is a combination of two existing registrations: the Registration Data and Information from the Dutch subsoil (deeper subsoil) (DINO) and the Soil Information System (BIS). It contains information about the geological and soil structure, underground infrastructure and usage rights. In a later stage information about archaeology and environmental quality will be added to the BRO.

### **Key Registers with no geographical component.**

#### Municipal Register of Persons/Inhabitants (GBA)

The GBA is the Municipal Key Register for personal data on each member of the Dutch population. This includes birth, marriage, moving, leaving for abroad, and death. The GBA contains all common personal data and amendments thereto, from the cradle to the grave.

#### Key Register of Vehicles (vehicle registration) (BRV)

In this data base vehicles and the owners are recorded. The National Agency for Road Traffic provides information to citizens and businesses.

#### Key Register Wages, Labour and Benefits (BLAU)

The current policy administration will be developed in this Key Register.

#### Key Register Incomes (BRI)

The Key Register Income (BRI) contains approximately the authentic income of thirteen million citizens. This is the total income, or if not available, the taxable year wage over the last calendar year. The tax authorities are responsible for the BRI.

#### Key Register Value Immovable Property (WOZ)

The WOZ contains information about the value of immovable property. Additional data can be recorded in this WOZ, such as the valuation date, specification of the object and the name of the person that received the WOZ value.

#### Registration Non-Residents (RNI)

The RNI records the non-residents in one registration. The RNI will work together with the GBA.

The first six Key Registers that have been developed and are appointed legal status include:

Population Register, Commercial Register, Key Register Cadastre, Key Register Topography, Key Register Addresses and Key Register Buildings.

### **Other national registers**

There are other Registers not belonging to the Key Registers, but serve as a national provision, managed by the Kadaster.

#### Spatial Plans

RO-Online is the portal through which the government makes digital spatial plans available. All spatial plans can be requested via RO-Online. The spatial plans are displayed as one image so that the user can see which spatial plans are available for a certain region.

#### Recognised Restrictions Immovable Property (WKPB)

The law Recognised Restrictions to Immovable Property (WKPB) has been prepared to ensure that it is easier to get complete information about the legal situation of a real estate at any given time.

All non-municipal restrictions that fall under the WKPB, will be registered by the Kadaster in its own administration. All municipal restrictions that fall under the WKPB, must be recorded in the municipal Registers. Kadaster manages the national provision.

#### Cables and Pipelines (KLIC)

The Dutch subsoil is full of cables and pipes. To prevent damage from digging and for the safety of the digger and the surrounding area, the Law Information-Exchange Subsoil Networks (WION), has been adopted. Kadaster is designated as the Service Provider. This means that Kadaster is the link between excavators and operators for the exchange of information about cables and pipes. The term KLIC is derived from the 'Cables and Pipes Information Centre '.

#### **Key Registers and INSPIRE**

Relevant for speeding up the realisation of the Dutch Key Registers is the European INSPIRE Directive, which enables spatial information to be harmonised among all European Union member states. INSPIRE has 34 themes (see column 1, in figure 4) and some of them can be directly linked to existing Dutch Key Registers. Data for the themes Geographical names, Administrative units, Addresses, Buildings, Cadastral parcels, Transport networks, Hydrography, and later Geology and Soil will be delivered from existing Key Registers. (see column 2, figure 4)

Nr	INSPIRE Themes	Key register as source 1)
	<b>Annex I</b>	
1	Coordinate reference systems	
2	Geographical grid systems	
3	Geographical names	Key Register Topography
4	Administrative units	Key Register Cadastre
5	Addresses	Key Register Addresses and Buildings
6	Cadastral parcels	Key Register Cadastre
7	Transport networks	Key Register Topography
8	Hydrography	Key Register Topography
9	Protected sites	
	<b>Annex II</b>	
10	Elevation	
11	Land cover	Key Register Topography
12	Orthoimagery	
13	Geology	Key Register Subsoil
	<b>Annex III</b>	
14	Statistical units	
15	Buildings	Key Register Addresses and Buildings
16	Soil	Key Register Subsoil
17	Land use	Key Register Topography
18	Human health and safety	
19	Utility and governmental services	
20	Environmental monitoring facilities	
21	Production and industrial facilities	
22	Agricultural and aquaculture facilities	
23	Population distribution – demography	
24	Area management/restriction/regulation zones and reporting units	
25	Natural risk zones	
26	Atmospheric conditions	
27	Meteorological geographical features	
28	Oceanographic geographical features	
29	Sea regions	
30	Bio-geographical regions	
31	Habitats and biotopes	
32	Species distribution	
33	Energy resources	Key Register Subsoil
34	Mineral resources	Key Register Subsoil
	<i>1) Also other datasets are used as source</i>	
	<i>Figure 4 Key register as source for INSPIRE themes</i>	

As we can see in figure 4 not all information for the INSPIRE themes is available in the key registers. There are a lot of other datasets with thematical geographical information available in the Netherlands. They need to be made in line with INSPIRE. The Key Registers together with the data for INSPIRE form the solid base of the National Spatial Data Infrastructure (NSDI). The portal for finding and exploring the NSDI is the National Georegistry for Discovery.

#### **The National Georegistry for Discovery, the metadata portal**

In this Registry, governments and companies can publish meta information to and from their own geographic databases. It is a place to find and explore all geo-information available in the Netherlands. The datasets of the Key Registers are only one part of all available geographical data in the Netherlands.

Governmental organisations such as ministries, provinces, water boards, and municipalities will share data for general use, and combine it with their own data and for different applications. Also datasets which will become available for the INSPIRE Directive, can be found via this portal. Many data providers have published metadata in recent years on their data sets and services. At the beginning of 2011 more than 2600 datasets are listed (see figure 5). The National Georegistry provides the most comprehensive central list of public sector information. Initiatives such as the introduction of the European INSPIRE Directive and the programme “Mapping Service for the Public” (PDOK) give a further boost to the portal. INSPIRE helps the availability, quality, organisation, access to and exchange of geo-information in Europe. It also links The Netherlands national provision, the National Georegistry, to a European network. The PDOK ensures that the National Georegistry will further be developed and managed.



Figure 5 The screen of the national georegistry

After searching for a special theme, the results are shown with some icons. These icons give more information on the datasets in terms of availability, costs, restrictions, et cetera (see figures 6 and 7).





Figure 6 Information about the datasets completed with icons

	Service		Show metadata in XML		Feedback
	Dataset		Valid MWS		Copy to clipboard
	Save result as PDF		Price information		Add to bookmarks
	Show map		Document reference		Non valid metadata
	Download data		Inspire dataset		Valid metadata
	Show metadata		User restrictions		Access restrictions

Figure 7 Explanation of icons used in the national georegistry

Figure 7 Explanation of icons, used in the national georegistry.

### Mapping Services for the Public (PDOK)

For a faster implementation of the National Spatial Data Infrastructure, some governmental organisations have started the project “Mapping Services for the Public” (PDOK) (in Dutch “Publieke Dienstverlening op de Kaart”). PDOK aims at shaping a better cooperation, service, lower management costs, and more common use of geo-information by developing a supply around geo-information. Participants are Ministry

of Infrastructure and Environment, Ministry of Economics, Agriculture and Innovation, TNO Geological Service of the Netherlands, Kadaster and Geonovum.

The objective is to provide geo-services internally between partners and externally to the public sector. Nation-wide front offices like “MijnOverheid.nl” and Geozet “Spatial Search and Portrayal Service” (Dutch: GEOgrafische Zoek- En Toondienst), are the first launching public customers of PDOK. In the future other national, regional, and local government agencies and services are expected to make use of PDOK services. PDOK fits well in government-wide initiatives like the Gideon strategy.

The implementation of PDOK is envisioned to be a growing system which will increasingly serve more datasets in the coming years. PDOK is a data-delivery service. The datasets maintenance is the responsibility of the PDOK partners. The Dutch Kadaster is the prospective maintenance organization of the central PDOK core service (including the access layer and the National Georegistry). In the coming years PDOK services will become more and more in conformance with the INSPIRE Directive.

To fulfill the expectations of future users, the system should provide good looking maps, be highly responsive, always available (7 x 24 hrs.) and provide meaningful services to its launching customers.

### **Conclusion**

The Key Registers in the Netherlands are a solid base for the National Spatial Data Infrastructure (NSDI). The Gideon report sets out the strategies to speed up the realisation of the Dutch NSDI. Also the link with the European INSPIRE Directive is a part of this strategy. The Cadastre, Land Registry and Mapping Agency (Kadaster) plays a central role in producing the Key Registers Cadastre and Topography and is also responsible for distributing other Key Registers as a national provision, for example Key Register Addresses and Buildings. In addition to the geographical Key Registers, there are more registers and datasets available. Together with the finished and development of other Key Registers, the Dutch NSDI becomes mature.

### **References**

- GIDEON – Key geo-information facility for the Netherlands, Ministry of Housing, Spatial Planning and the Environment, Den Haag, 2008
- Report Technical Design PDOK Motor Phase 1, Geonovum, 2010
- Napoleon’s registration principles in present times: The Dutch System of Key Registers, Yvette Ellenkamp, Bart Maessen. Published as paper in GSDI 11. 2009
- Website: [www.geonovum.nl](http://www.geonovum.nl)
- Website: [www.nationaalgeoregister.nl](http://www.nationaalgeoregister.nl)
- Website: <http://www.rijksoverheid.nl/onderwerpen/basisregistraties>
- Website [www.kadaster.nl](http://www.kadaster.nl)

### **Abbreviations**

<b>Abbreviation</b>	<b>Name</b>
BAG	<u>Key Register Addresses and Buildings</u>
BAGLV	national provision
BGT	<u>Key Register Large-scale Topography</u>
BIS	Soil Information System
<u>BLAU</u>	<u>Key Register Wages, Labour and Benefits</u>
<u>BRI</u>	<u>Key Register Incomes</u>
BRK	<u>Key Register Cadastral Parcels</u>
BRO	<u>Key Register Subsoil</u>
<u>BRT</u>	<u>Key Register Topography</u>
BRV	<u>Key Register of Vehicles</u>
DINO	Registration Data and Information from the Dutch subsoil
GBA	<u>Municipal Register of Persons/Inhabitants</u>
GBKN	Large-scale Base Map of the Netherlands
Kadaster	Cadastral, Land Registry and Mapping Agency
<u>KLIC</u>	Cables and Pipes Information Centre
NHR	<u>New Commercial Register</u>
<u>NSDI</u>	<u>National Spatial Data Infrastructure</u>
PDOK	Mapping Service for the Public
<u>RNI</u>	<u>Registration Non-Residents</u>
SDIs	Spatial Data Infrastructures
WION	Law Information-Exchange Subsoil Networks
<u>WKPB</u>	<u>Recognised Restrictions Immovable Property</u>