

## AUTOMATICALLY GEOREFERENCED MAPS AS A SOURCE FOR HIGH RESOLUTION URBAN GROWTH ANALYSES

HEROLD H.(1), ROEHM P.(2), HECHT R.(1), MEINEL G.(1)

(1) *Leibniz Institute of Ecological and Regional Development, DRESDEN, GERMANY* ; (2) *Dresden University of Technology, DRESDEN, GERMANY*

### ABSTRACT

This paper addresses the automation of georeferencing topographic maps for the operational acquisition of spatiotemporal data on urban growth. The achieved automation of this process helps to overcome some issues and hindrances of costly manual data preparation and, thus, enables high resolution monitoring and GIS-based analyses of urban dynamics on a regional and, even, national level. Despite temporal and spatial uncertainties inherent to topographic maps, initial results indicate great potential for the obtained information. The data has proven valuable for quantitatively measuring and visualizing the creeping, but persistent, process of urban sprawl. Possible fields of application involve high resolution monitoring of land take with regards to sustainable development, the exploration of settlement patterns over time, and the quantitative validation of urban spatial growth models.

### KEYWORDS

urban growth, topographic maps, georeferencing, image segmentation, GIS

### 1. INTRODUCTION

Contemporary and historic topographic maps have been demonstrated as valuable sources for deriving primary or ancillary data for both landscape and urban research (e.g., Kienast 1993, Leyk 2005, Meinel *et al.* 2009, Perret *et al.* 2009, and Knoblock *et al.* 2010). As remotely sensed imagery, topographic maps contain and preserve snapshots of landscape and settlement patterns at a certain point in time. In contrast to other primary sources of geospatial information, such as remote sensing imagery or cadastral data, topographic maps are primarily inexpensive, available nationwide, have defined update intervals, and are predominantly homogeneous for large areas and longer periods of time. In order to make the implicit information contained in the scanned paper documents digitally available, image processing and segmentation techniques have to be applied. Thus, automated map interpretation and information retrieval has been an important matter of research for decades. Pattern recognition algorithms for the cartographic symbols have been developed in order to derive the relevant information (e.g., Suzuki and Yamada 1990, Frischknecht and Kanani 1997). When aiming for spatial analyses within Geographic Information Systems (GIS), the maps have to be georeferenced. Considering operational, large scale, and long term monitoring applications, hundreds of topographic map sheets have to be manually prepared. In order to overcome the limitation of GIS-based analyses to regional case studies, due to the costly manual data preparation, an automatic procedure has been developed.

### 2. METHODOLOGY

The presented approach comprises two steps. In the first step, the scanned topographic map documents are automatically georeferenced. Subsequently, the relevant building information is retrieved by automated map interpretation. The common workflow for georeferencing raster images is as follows: the user visually identifies ground control points within the unreferenced map and refers them to real world coordinates. The latter can be done by either manually keying in the coordinates or by visual assignment to corresponding points in a referenced map representing the same area. Most software applications in the fields of geographic information science and image processing support this procedure. In order to assist the user with the time consuming process of loading the map files and zooming between the map corners, Jatnieks (2010) suggests a semi-automated method realized as a plug-in for the open source software QuantumGIS. Although the plug-in offers universal applicability, the user still has to assign the pixel positions in the original map sheets.

When aiming at a complete automation of the process, potential reference points have to be homogeneously distributed, readily identifiable, and their real world coordinates have to be known. These objects can be, e.g., intersections of coordinate lines represented by either single crosses or a grid over the entire map. Titova and Chernov (2009) propose a method for the identification of these grid crosses in binary and greyscale map images. The method enables an automatic search for parameters of image errors of topographic plans to accomplish automatic image correction. Another approach to automated map referencing is presented in Rus *et al.* (2010), which requires a completely delineated coordinate grid.

In our approach, we aim at handling and processing a multitude of maps with varying layouts. That is, the least common features for referencing are the map margins and map identifiers comprising number and name. The corresponding real world coordinates of the map corners can be inferred from the national map sheet line systems. As only four points of each map can be used for referencing, the method assumes a sufficient image quality for the given task and application. Corrections of image distortions, other than affine transformations, are not possible. First, starting from the detection of the map frame, the location of the map identifier is detected. The classification of the comprised map number is performed by using a multilayer perceptron (MLP) based classifier (Steger *et al.* 2008). Hereby, the optical character recognition procedure can easily be adapted to other map characters and fonts. Figure 1 shows an example of a detected and correctly recognized map number.

Subsequently, the interior map margins at the four edges of the image are extracted. This is achieved by means of a sequence of morphological filtering operations. The results are three to six pixel wide lines. In order to obtain a representative straight line function for the interior margins, a best-fit linear regression line is calculated. By using the intersections of the regression lines of the interior margins to derive the pixel coordinates, a robust map corner detection is achieved (cf. Figure 2).

4 1 0 3

# 4103 Emmerich

Figure 1. Automatically segmented map identifier comprising number and name. The map number is classified by means of an MLP based optical character recognition (OCR) algorithm.

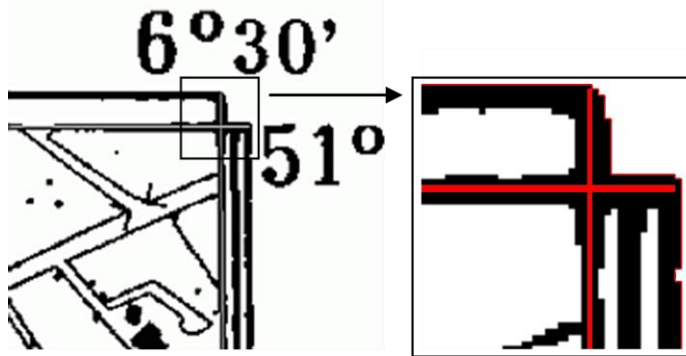

Figure 2. Automated detection of map frame and construction of reference points at the intersections of regression lines of the interior map margins.

By means of the map sheet line system of the German Topographic Map at a scale of 1:25,000 and the recognized map sheet number, it is possible to compute the real world coordinates of the upper left corner and, thus, also of the remaining coordinates. Finally, the real world coordinates are assigned to the pixel coordinates of the map image. Hence, the map is georeferenced and can be included in the data retrieval and analysis process.

The extraction of building footprints is based on morphological operations. Common topographic maps comprise the substantive elements in a binary manner, displaying buildings, traffic, vegetation symbols, and lettering elements merged in one layer (ground plan). In contrast to commonly used remote sensing imagery for change detection applications, there is neither spectral nor textural information available. Differentiation of map objects, e.g. in a set of building and non-building features, can only be achieved by considering their morphological characteristics. For morphological image segmentation a morphological opening (erosion followed by dilation) can be applied. With optimal parameterization the basic image processing algorithm already produces good results. However, some cartographic representations and letterings have similar morphological characteristics as buildings and, consequently, are misclassified. Therefore, an adaptive object recognition algorithm for lettering and symbols has been developed, introducing a priori knowledge about morphological characteristics of representations such as compactness, convexity, and anisometry to the segmentation process (Meinel *et al.* 2009, Herold *et al.* 2010). Finally, all detected symbol and lettering objects are subtracted from the original image using basic map algebra. The method has been implemented using both the geoprocessing scripting engine in ArcGIS and the image analysis and processing software Halcon.

### 3. EVALUATION AND RESULTS

An initial implementation of the presented approach has been applied to a series of German topographic maps at a scale of 1:25,000. For accuracy assessment, a set of manually selected reference points is compared to the points created by the algorithm. The performance of the algorithm is assessed by measuring the displacement of the corresponding pixels. The initial results indicated the algorithm to be robust. The automatic detection yielded a median displacement distance of 1.07 pixels with a standard deviation of 0.49. After applying the described building extraction method to georeferenced maps from points in time, the evolution of buildings can be modelled by their appearance and disappearance within the dataset. The results can be displayed, analyzed, and combined with ancillary data in a Geographic Information System. Figure 3 shows a sample visualization of building data solely inferred from a multi-temporal series of topographic maps. In this way, visualization and geospatial analyses of large areas can be efficiently accomplished. The retrieved data can help to constitute spatiotemporal databases on urban dynamics as suggested in Perret *et al.* 2009. In order to combine the obtained map based data with more detailed or up to date databases, conflation algorithms, as well as, the modelling of multiple representations of objects (Burghardt *et al.* 2010) have to be considered.

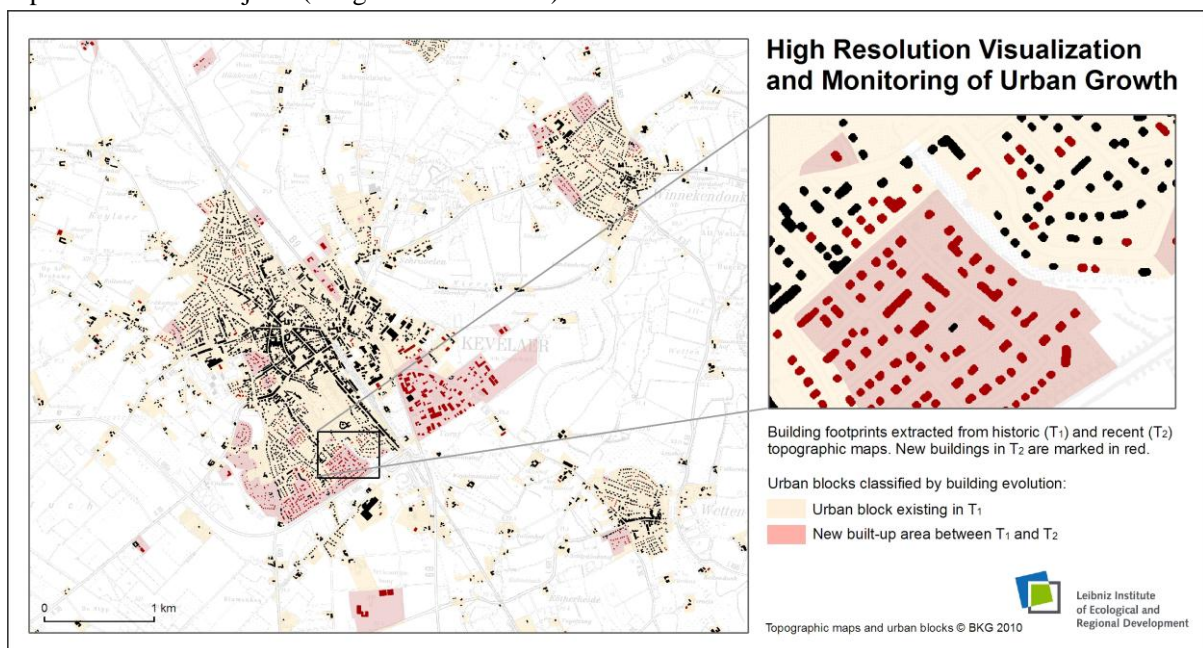

Figure 3. Detailed visualization and monitoring of urban growth. Spatiotemporal data on building objects are operationally retrieved from a multi-temporal series of 1:25,000-scale topographic maps.

### 4. CONCLUSION AND PERSPECTIVES

In this study, we presented an approach to automatically georeference topographic maps in order to retrieve building based spatiotemporal information in an operational way. The achieved automation of this process helps to overcome some issues and hindrances of the costly manual data preparation such that it enables high resolution monitoring and analyses of urban dynamics on a regional and national level. Despite temporal and spatial uncertainties, such as object variability, image distortions, and generalization effects inherent to topographic maps, initial results indicate great potential for the method and obtained information. The data have proven valuable for quantitatively measuring and visualizing the creeping, but persistent process, of urban sprawl. Incorporated within GIS-based Spatial Planning Support Systems, the data can assist planners and decision makers to evolve sustainable urban development strategies and action plans. Possible fields of application involve the large scale monitoring of land take, the evaluation of zoning rights and practices in light of sustainability, the identification of potential areas for infill developments, the exploration of settlement patterns over time, and the validation of urban growth models and simulations. The operational application of the approach and its findings will foster a nationwide web-based monitoring system of the settlement and open space development (Meinel 2010) that is currently been developed at the Leibniz Institute of Ecological and Regional Development. Current and future research encompasses both the algorithm adaptation to other map scales and layouts for cross-border and longer term monitoring, as well as, the conflation of the map based data with recently available precise building data from digital up to date cadastral databases.

## REFERENCES

- Burghardt, D., Petzold, I. and Bobzien, M. 2010. Relation Modelling within Multiple Representation Databases and Generalisation Services. *The Cartographic Journal*, 47(3), p. 238-249.
- Frischknecht, S. and Kanani, E. 1997. Automatic Interpretation of Scanned Topographic Maps: A Raster-Based Approach. *Lecture Notes in Computer Science*, 1389, p. 207-220.
- Herold, H., Meinel, G. and Csaplovics, E. 2010. An Approach to Spatio-Temporal Information Retrieval from Map Series for Monitoring Urban Dynamics. In *Proceedings of the GIScience 2010 DC*, Zurich, Switzerland, p. 41-44.
- Jatnieks, J. 2010. Open Source Solution for Massive Map Sheet Georeferencing Tasks for Digital Archiving. *Lecture Notes in Computer Science*, 6102, p. 258-259.
- Kienast, Felix. 1993. Analysis of historic landscape patterns with a Geographical Information Systems (GIS) - a methodological outline. *Landscape Ecology*, 8(2), p. 103-118.
- Knoblock, C. A., Chen, C., Chiang, Y., Goel, A., Michelson, M. and Shahabi, C. 2010. A general approach to discovering, registering, and extracting features from raster maps. In *Proceedings of the Conference on Document Recognition and Retrieval XVII of SPIE-IS&T Electronic Imaging*, 7534, San Francisco, USA, 15 p.
- Leyk, Stefan. 2005. Computing the Past - Utilizing Historical Data Sources for Map-Based Retrospective Landscape Research. *Ph.D. thesis*, University of Zurich.
- Meinel, G., Hecht, R. and Herold, H. 2009. Analyzing building stock using topographic maps and GIS. *Building Research & Information*, 37(5), p. 468-482.
- Meinel, G. 2010. Monitoring of Settlement and Open Space Development on the Basis of Topographical Spatial Data - Concept, Realization and first Results. In *Core Spatial Databases - Updating, Maintenance and Services - from Theory to Practice*, ISPRS International Archives of the Photogrammetry, Remote Sensing and Spatial Information Sciences, Haifa, Israel, p.132-137
- Perret, J., Mas A. B. and Ruas, A. 2009. Understanding Urban Dynamics: the use of vector topographic databases and the creation of spatio-temporal databases, In *Proceedings of the 24th International Cartography Conference (ICC 2009)*, Santiago, Chile.
- Rus, I., Balint, C., Craciunescu, V., Constantinescu, S., Ovejanu, I. and Bartos-Elekes, Z. 2010. Automated georeference of the 1: 20,000 Romanian maps under Lambert-Cholesky (1916-1959) projection system. *Acta Geodaetica et Geophysica Hungarica*, 45(1), p. 105-111.
- Steger, C., Ulrich, M. and Wiedermann, C. 2008. Machine Vision Algorithms and Applications. Berlin, WILEY-VCH.
- Suzuki, S., and Yamada, T. 1990. MARIS: map recognition input system. *Pattern Recognition*, 23(8), p. 919-933.
- Titova, O. A. and Chernov, A. V. 2009. Method for the automatic georeferencing and calibration of cartographic images. *Applied Problems - Pattern Recognition and Image Analysis*, 19(1), p. 193-196.